

# DAVIS 346 AER

346 x 260



- Prototype DAVIS sensor in 180nm CIS technology
- Concurrent QVGA+ resolution event and frame output from single sensor via USB
- Event-only output via AER connector
- Event output with up to 120dB dynamic range, sub 1  $\mu$ s latency, 1 $\mu$ s temporal resolution and up to 12 million events per second throughput
- 6-axis IMU, up to 8k Hz sampling rate
- Consumes less than 180mA at 5V power supply
- Anodized aluminium case with CS lens mount, 4-side mounting options, screw-locked USB port

## Specifications

### Event output

Spatial resolution	346 x 260
Temporal resolution <sup>1</sup>	1 $\mu$ s
Max throughput	12 MEPS
Typical latency <sup>2</sup>	<1 ms
Dynamic range	Approx. 120 dB (0.1-100k lux with 50% of pixels respond to 80% contrast)
Contrast Sensitivity	14.3% (on), 22.5% (off) (with 50% of pixels respond)

### Frame output

Spatial resolution	346 x 260
Frame rate	40 FPS
Dynamic range	55 dB
FPN	4.2 %
Dark signal	18000 e <sup>-</sup> /s
Readout noise	55 e <sup>-</sup>

### IMU

6-axis (Gyro + Accelerometer), up to 8k Hz sampling rate

## Multi-camera sync

-

## Other attributes

Dimensions [mm]	H 40 x W 60 x D 25
Weight	100 g without lens
Lens mount	CS-mount
Case material	Anodized aluminum
Mounting options	4-side Whitworth 1/4"-20 female and M3 mounting points
Connectors	USB 3.0 micro B port with locking screws, AER connector 2.54mm pins
Power consumption	<180 mA @ 5 VDC (USB)
Sensor technology	0.18 $\mu\text{m}$ 1P6M MIM CIS
Pixel pitch [ $\mu\text{m}$ ]	18.5 $\mu\text{m}$
Sensor supply voltage	1.8 V and 3.3 V
Certifications	CE certification pending

*Specifications not guaranteed. All specifications subject to change without notice*

<sup>1</sup> The temporal resolution is characterized by the timestamp unit. In fact, a timestamp unit of 1  $\mu\text{s}$  offers minimum gain over a timestamp unit of 200  $\mu\text{s}$ . For more explanation, please refer to our [white paper](#).

<sup>2</sup> Nominal figure; can be improved with strong lighting/optimised biases.

## Limitations:

- In APS GlobalShutter mode, bursts of DSV events can be caused by the capture of an APS frame.
- Due to bandwidth limitations, the DVS event output tends to follow a scanning pattern when under high load.
- The frame output has below average performance in terms of image quality compared to conventional image sensors.
- Color frames are not calibrated, and thus do not faithfully reproduce the real observed color.
- The event output can be destabilized if a strong light source impacts a sensitive spot outside the photosensitive pixel array.
- The AER connector can only transmit events, not frames or IMU data.
- No multi-camera timestamp synchronization is present, nor triggers.

## Physical dimensions

The DAVIS 346 AER camera is housed in an anodized aluminum case. The case dimensions are depicted below.

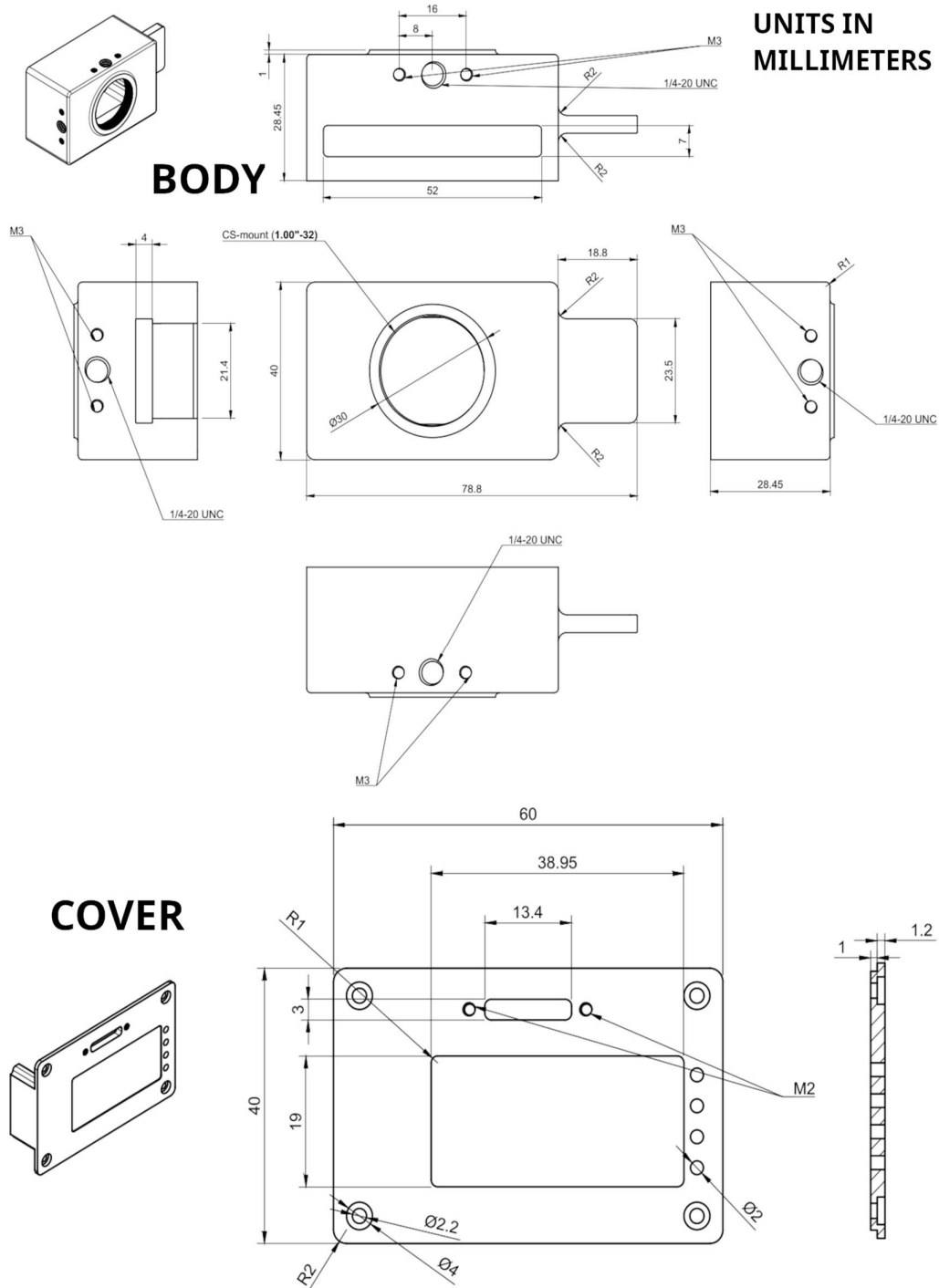

Figure 1 Dimensions of the DAVIS 346 AER camera case

## Connectors

DAVIS 346 AER has one USB 3.0 connector for data and power on its back, as well as an AER connector to the side. Please note no timestamp synchronization and/or trigger connectors are provided on this model!

### USB 3.0 connector

The USB 3.0 connector is used for data and power. Any USB 3.0 or USB 2.0 cable with micro B connector can be used. However, USB 3.0 speeds are only supported when using a USB 3.0 cable. Usage of cables with appropriate locking screws are recommended for a more secure and robust connection.

### AER connector

The AER connector is located on the side, as shown in the following image:



It consists of 16 (2x8) 2.54mm pins. The exact pinout is marked on the connector itself, as shown here:



## AER protocol format

The AER protocol is a simple protocol using a variable number of lines (bus) to transmit data, and two lines (REQ and ACK) to synchronize the data between the sender and the receiver asynchronously using a four-phase handshake (this is also called a bundled asynchronous protocol).

The ACK and REQ lines are active-low.

This is how the protocol looks from the receiver's perspective, where REQ is to be considered an input and ACK an output:

1. The receiver waits for the REQ line to be asserted by the sender
2. At this point, the data on the bus can be considered valid and stored
3. The receiver confirms having read the data by asserting ACK
4. It then waits until the sender has again deasserted REQ, deasserts ACK itself and goes back to wait in (1) for the next transaction

The following website has number of very detailed explanations for further reading:

<https://www.cl.cam.ac.uk/~djg11/wwwhpr/fourphase/fourphase.html>

Also, for details on AER, please look at:

<https://www.ini.uzh.ch/~amw/scx/std002.pdf>

For FPGA implementations, we recommend synchronizing at least the REQ input using a double-flip-flop synchronizer. Data itself should also be synchronized in this way, or by connecting it directly to a register with an Enable signal and enabling it only during phase (2).

All current iniVation DAVIS sensors employ a serial data format, meaning that the X and Y addresses are not output concurrently, but separately one after the other.

One extra data bit, called XSelect, is used to disambiguate between the two types of address.

Current sensors employ a row-wise readout scheme, so a Y (row) address will always be followed by a series of one or more X (column) addresses. The column address will also contain the Polarity information bit.

Further, we recommend inserting a delay of ~50ns between REQ and getting the data (phases 1 and 2), because the current sensors violate the assumption that all data lines are always valid and stable before REQ is asserted. The XSelect bit can be considered valid right away, but for Y addresses this delay should be observed. X addresses can also be captured right away.

NOTE: DAVIS sensors may produce glitches known as "row-only events", where a Y (row) address is followed immediately by another Y (row) address. In this case, just discard the earlier address.

The format for DAVIS346 AER is documented in detail below:

```
AER bus width: 11 signals = 10 (9 downto 0) + XSelect
```

```
if XSelect = '1' then
```

```
    X Address, address is: 9 bits, 9 downto 1, polarity on 0
```

```
else
```

```
    Y Address, address is: 9 bits, 8 downto 0, 9 is don't care
```

```
end if;
```

## Optics

The camera lens mount is designed to accommodate CS-mount lenses. Other lenses can be accommodated by using adapters. The standard lens shipped with the camera is a C-mount lens and ships with an adapter. The chip requires a lens designed for 1/3-inch imagers.

The field of view (FOV) depends on the focal length  $L$  of the lens and the size  $W$  of the pixel array. It is computed from geometrical optics, not accounting for any lens distortion. The angular field of view ( $AFOV$ ) is given by:

$$AFOV = 2 \tan^{-1} \left( \frac{W}{2L} \right)$$

The linear FOV ( $LFOV$ ) at a distance  $D$  from the lens is given by

$$LFOV = D * W / L$$

The pixel array has a resolution of 346 x 260 and measures:

- Width: 346 pixels x 18.5 um/pixel = 6.4 mm
- Height: 260 pixels x 18.5 um/pixel = 4.81 mm

The following table shows the horizontal and vertical field of view in degrees and its size at various distances for different common focal lengths.

### Computations of Field of View

Lens focal length [mm]		2.1	3.5	4.5	6	12
Angular field of view horizontal [deg]		113	84.9	70.8	56.2	29.9
Angular field of view vertical [deg]		97.7	69	56.2	43.7	22.7
Angular field of view diagonal [deg]		125	97.7	83.3	67.4	36.9
Linear field of view horizontal [cm]	dist. 10 cm	30.5	18.3	14.2	10.7	5.33
	dist. 30 cm	91.4	54.9	42.7	32	16
	dist. 100 cm	305	183	142	107	53.3



## Software

DAVIS 346 AER is compatible with the DV software platform. Go to [www.inivation.com](http://www.inivation.com) to access the newest version of the software and SDK.

To enable the AER output connector, in DV open the “Capture” module full configuration (+ sign) and turn on the “ExternalAERControl” parameter.

For a low-level approach, there is also an example using libcaer to enable this feature on our developer website:

[https://gitlab.com/inivation/dv/libcaer/-/blob/master/examples/davis\\_enable\\_aer.cpp](https://gitlab.com/inivation/dv/libcaer/-/blob/master/examples/davis_enable_aer.cpp)

## Serial number

The serial number of the device can be found on the case, usually a four-digit number printed on a black label located at the top of the camera case.

## Package contents

DAVIS346 AER ships with the following items

- DAVIS346 AER camera
- USB 3.0 cable, 1m with locking screws
- Varifocal C mount lens
- CS to C mount lens adapter